



*Making a Splash!*

# Owners Manual

## VFX Aerating Fountains

2400VFX, 3400VFX, 3400HVFX, 4400VFX,  
4400HVFX, 8400VFX, 5.1VFX

### Contents

Important Safety. . . .	pg2
General Instructions. . . .	pg2
VX Pattern Sizes. . . .	pg4
Cord Gauge Chart. . . .	pg4
Unit Specs. . . .	pg4
2400, 3400, 4400VX Parts Chart. . . .	pg4
2400VFX, 3400(H)VFX, 4400(H)VFX Parts Included. . . .	pg5
2400VFX, 3400(H)VFX, 4400(H)VFX Assembly. . . .	pg5
8400VFX & 5.1VFX Parts. . . .	pg7
8400VFX & 5.1VFX Assembly. . . .	pg7
VFX Installation Instructions. . . .	pg9
Control Panel Installation. . . .	pg10
C-25 Timer Control Instructions. . . .	pg11
C-85 Control Instructions. . . .	pg12
C-95 Control Instructions. . . .	pg13
Maintenance Recommendations. . . .	pg14
Warranty Policy. . . .	pg15
Troubleshooting Tips. . . .	pg17
2400, 3400, 4400 Parts Diagram. . . .	pg19
8400VFX Replacement Parts. . . .	pg20
5.1VFX Replacement Parts. . . .	pg21
Customer Repair Form. . . .	pg22
Registration Information. . . .	pg23



Kasco Marine, Inc.  
800 Deere Rd.  
Prescott, WI 54021  
PH (715) 262-4488  
FAX (715) 262-4487  
[www.kascomarine.com](http://www.kascomarine.com)



## THANKS

We at Kasco Marine, Inc. would like to both thank and congratulate you on your purchase of the VFX model aerating fountain. We appreciate you choosing Kasco and for your purchase. Your decision to purchase Kasco's VFX model Aerating Fountain will not disappoint you. The VFX model Aerating Fountain will be a great addition to your body of water. It will help improve the water quality by adding much needed oxygen and circulation. It will also enhance the aesthetics of the pond or lake with a beautiful fountain pattern. The lighting package (if purchased) will illuminate your fountain for beauty at night. We thank you for choosing Kasco for your fountain needs and want you to be completely satisfied with your purchase.

## Important Safety

Please read and follow these extremely important safety and handling instructions for your Kasco equipment. Following these instructions will help ensure your safety and the quality performance of your equipment.

- Under NO circumstances should anyone enter the water with the electrical equipment plugged in and/or in operation. All Kasco equipment is ETL approved to UL and CSA standards for safety in water and all fountain models include control panels with GFI protection. However, it is NEVER recommended to enter the water with the equipment in operation.
- Caution should be used when dealing with any electrical equipment with moving parts.
- NEVER run the unit out of water. It will damage the seals and create a dangerous situation for the operator.
- Extreme caution should be used around wa-

ter, especially cold water, such as in Spring, Fall, and Winter, which poses a hazard in and of itself.

- NEVER lift or drag the fountain by the power or light cord. If you need to pull the unit to the side of the pond, use the anchoring ropes.
- Do not use waders in deep ponds/lakes or ponds/lakes with drop-offs, drastic slopes, or soft bottom material.
- Do not use boats that tip easily for fountain installation, such as a canoe, and follow all boating safety rules and regulations, including wearing a PFD. (Personal Flotation Device)
- The fountain is supplied with an internal grounding conductor and a grounding-type attachment plug. To reduce the risk of electrical shock, be certain that the fountain is plugged into the C-25 Control Box (120V), C-85 or C-95 Control Panel (240/208V) supplied by Kasco and that the C-25 is plugged into a properly grounded, grounding type receptacle or the C-85 and C-95 is wired properly. The GFCI breakers should be tested upon each installation and every month thereafter to ensure proper operation.

## General Instructions

### INSPECT THE SHIPMENT

Immediately inspect your Kasco Fountain shipment for any visible damages. Also cross reference the parts supplied with the Parts Included sheet to check for shortages. Shortages should be reported immediately to your Kasco Marine distributor or representative and damages reported to your carrier and Kasco Marine.

## CAUTION

**WARNING:** Under NO circumstances should anyone enter the water with the unit in operation. Always operate the unit in the water and keep people and objects clear of the propeller. Do not lift or pull the unit by the electrical cord. Always use extreme caution around electrical equipment and water situations.

## ASSEMBLY & INSTALLATION

Please see the proper Assembly and Installation Instructions enclosed in this manual. Each is specific for your model and size of Fountain. Note: Use a nylon tie to help keep the power cords for the unit and lights free of the propeller by tying each cord to either side of the float. If you have a light kit, make sure that the unit cord is tied to one side of the float and the light cord to the other for balance.

Note: It is extremely important to test the GFI breaker in the control panel upon each installation/reinstallation of the unit to ensure proper functioning.

## WARRANTY

Kasco Fountains are the result of over 35 years of design and engineering. Kasco products are built to withstand the toughest conditions. Kasco Marine backs each VFX model Fountain with either a 2 Year or 3 Year Warranty depending on the model. This warranty covers any and all manufacturers defects within the warranty period from the date of purchase (See Warranty Section). Please register your Fountain online at:

[www.kascomarine.com](http://www.kascomarine.com) (under the technical tab)

## USE AND OPERATION

Kasco Fountains are designed and engineered for continuous duty, such as on fish farms or other aquaculture applications, or on-demand use, as needed in a recreational water feature.

During flotation operation, the water is pulled from 360° around the unit and from below the unit. The water is pulled upward and thrust through the flotation collar into the air.

Your Kasco Marine Fountain is ready for immediate use (after installation). The motor and ball bearings are submerged in oil and no further lubrication is needed. Make sure to keep the motor housing clean from hard water deposits and/or algae. (See Maintenance Recommendations.)

It is extremely important that proper and sufficient voltage (120V or 240/208V) is supplied to the Fountain motor. Each 120V Fountain is supplied with a UL and CSA approved C-25 GFI Protected Control Box. The Fountain is to be plugged into the C-25 outlet labeled "UNIT" and the C-25 plugged into a properly grounded receptacle (See C-25 Instructions on page 12). Each 240V Fountain is supplied with a UL and CSA approved C-85 or C-95 GFCB Protected Control Panel. The Fountain is to be plugged into the external outlet on the C-85 or hardwired into C-85 or C-95 panel. The C-85 & C-95 must have 4 wire service (L1, L2, neutral, and ground) installed by a qualified electrician. (See Wiring Instructions). It is extremely important to test the GFI breaker in the control panel upon each installation and reinstallation and every month thereafter to ensure proper operation.

Kasco Fountains are lightweight, energy efficient, and easy to install and operate. We strive to produce products that exceed customer expectations. We hope you enjoy your Kasco Fountain.

## VX Pattern Sizes

NOTE: Pattern sizes listed are approximate. Variations in voltage caused by regional electrical differences or voltage drop due to long power cords may result in reduced pattern sizes.



Model	Voltage	Height	Width
2400VFX	120	5'	15'
3400VFX	120	6'	21'
3400HVFX	240	6'	21'
4400VFX	120	8'	26'
4400HVFX	240	8'	26'
8400VFX	240	8'	32'
5.1VFX	240	9'	34'

## Cord Gauge Chart

Length	Gauge	2400	3400	3400H 4400H	4400	8400	5.1
50'	16	x	x				
50'	14			x	x	x	
100'	14	x	x	x			
100'	12				x	x	x
150'	12	x	x	x		x	
150'	10				x		x
200'	12	x	x	x		x	
200'	10				x		x
250'	12			x		x	
250'	8						x

## Unit Specs

Model	Voltage	Amps	Lock rotor amps	Control box connection	Fountain connection
2400VFX	110-120	5.6	12	C-25 plug in	Plug into C-25
3400VFX	110-120	7.3	18	C-25 plug in	Plug into C-25
3400HVFX	208-240	3.7	9	Hardwire C-85	plug into or hardwire C85
4400VFX	110-120	11.3	40	C-25 plug in	Plug into C-25
4400HVFX	208-240	5.7	20	Hardwire C-85	plug into or hardwire C85
8400VFX	208-240	11	40	Hardwire C-85	plug into or hardwire C85
5.1VFX	208-240	20	97	Hardwire C-95	hardwire C95

## 2400, 3400, 4400VX Parts Chart (Corresponds to Parts Diagram)

#	2400VFX	3400VFX/ 3400HVFX	4400VFX/ 4400HVFX	Part Name	Qty
1	241000	241000	241000	XF Float	1
2	990162	990162	990162	Bottom Screen	1
3	223240	223240	223240	Bottom Screen Clips	2
4	241005	241005	241005	X tube	1
5	140312	140312	140312	Retainer Clip	4
6	258476	258476	258476	1/4" flat washer	4
7	462210	462210	462210	3/8" x 1 3/4" bolt	2
8	462214	462214	462214	3/8" Nylon locking nut	2
9	462216	462216	462216	3/8" washer	4
10	251200	251200	251200	1/4" x 3 1/4" machine screw	4
11	251250	251250	251250	#14x1 1/4" self tapping screw	4
12	240594	340594	440600	VX prop	1
13	241025	241035	241045	VX Disc	1
14	243405	243405	243405	1/2"x3/4" V disc bolt	1
15	475642	475642	475642	1/2" Flat washer	1
16	990281	990281	990281	sealing washer	1
17	990280	990280	990280	Sealing plug	1
18	990275	990275	990275	Cord oring	1
19	251300	251300	251300	1/4 washer .75 O.D.	4
20	243475	243475	243475	zinc anode	1

## 2400VFX, 3400(H)VFX, 4400(H) VFX Parts Included

1. 3400JF Aerating Fountain (Unit with cord or unit with Disconnect) (1)
2. Float (with two 50' mooring ropes attached) (1)
3. 1/4-20 x 3 1/4" Phillips Pan Head Screw (4)
4. 1/4" split washers (4)
5. 1/4" (3/4" outer diameter) Flat Washer (4)
6. 3/8"-16 x 1-3/8" Hex Head Bolt (2)
7. 3/8" Flat Washer (4)
8. Cushions for Legs (4)
9. Bottom Screen Cushion (3)
10. Bottom Screen (1)
11. Bottom Screen Clips (2)
12. 3/8"-16 Nylon Lock Nut (2)

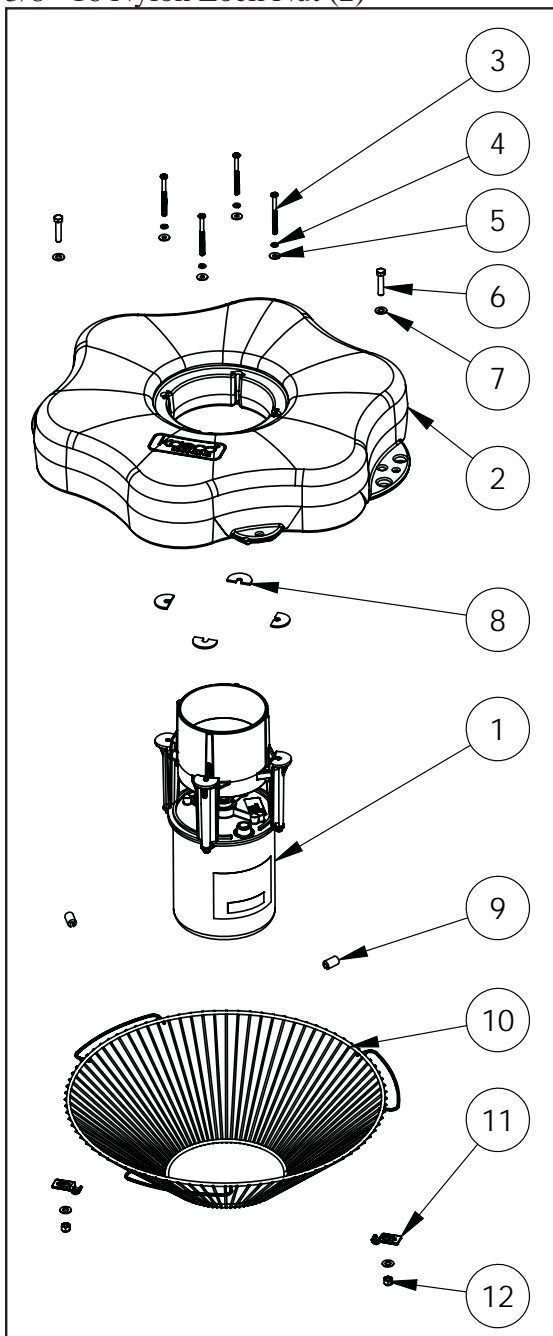

### Also Included:

- Cord in separate box (1) (depending on size of cord)
- Control Box (C-25 for 120V units in Float box or C-85 for 240V units in separate box) (1) (Not Pictured)

### TOOLS & SUPPLIES NEEDED

- Anchors or stakes for installing unit (2)
- # 2 Phillips head screw driver
- 120V or 240V Electrical Supply near pond on a post with room for mounting the C-25 or C-85
- Two 12" pieces of 1" galvanized pipe for weight-ing ropes (optional)
- #10 x 1" long or longer screw(s) for mounting the C-25 (3) or C-85 (4)
- 9/16" Socket and Ratchet
- 9/16" Wrench

## 2400VFX, 3400(H)VFX, 4400(H) VFX Assembly

### STEP ONE

Make sure you have all the parts needed. If any shortages are found, contact your Kasco representative immediately.

### STEP TWO

Set motor housing upright (stainless steel can down) on a flat surface.

### STEP THREE

Peel off the adhesive on one of the Cushions for the fountain housing legs (Part 8). Stick to the top of the fountain housing leg and repeat for the other three cushions. Rest the float on the 4 legs of the housing making sure logo on float is up.



### STEP FOUR

Ensure correct alignment by twisting the float gently around the motor housing until the power cord guide

lines up with the cord. See diagram below of bottom side of float. The 4 bolt holes in the float should line up with bolt receptacles on unit.

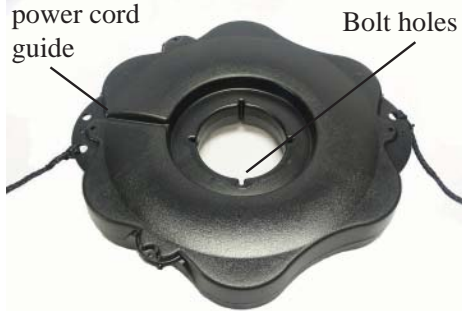

#### STEP FIVE

Use one of the 1/4"-20 x 3-1/4" Phillips Pan Head Screws (Part 3), one 1/4" split washer (Part 4), and a 1/4" Flat Washer (Part 5) to secure the float. Make sure the split washer goes between the bolt head and the flat washer. Insert screw with washers through bolt hole in float

Tighten until snug with a Phillips Head screw driver and repeat for 3 remaining screws.



#### STEP SIX

Turn secured assembly upside down so the top of the float (logo side) is face down on the flat surface. Place Bottom Screen (Part 10) onto the bottom side of the float. Make sure the wide opening of the screen is against the float and the 3 handles on the screen do not interfere with the rope placements. Fit the 3 Bottom Screen cushions (Part 9) underneath the screen and on top of the 3 spacing bumps on the bottom of the float.

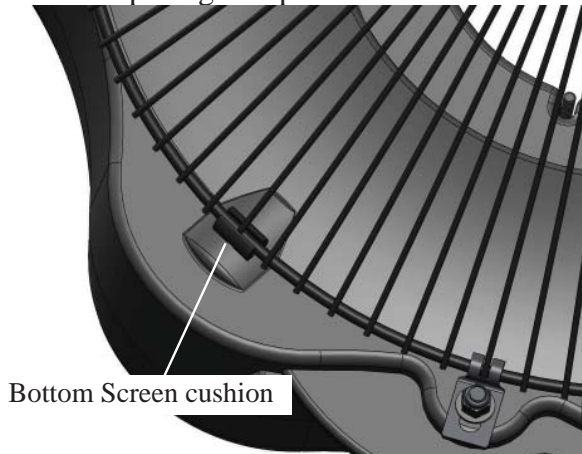

#### STEP SEVEN

Using a stainless steel Bottom Screen Clip (Part 11),

3/8"-16 x 1-3/8" Bolt (Part 6), two 3/8" Flat Washer (Part 7), and 3/8"-16 Nylon Lock Nut (Part 12) to secure the screen to the float. Align a clip so the two prongs straddle a wire on the screen. Insert bolt with washer so the top of the bolt is facing the top of float (now in down position). Place the second washer and the locking nut with nylon insert on the end of the bolt and tighten using the 9/16" (14mm) Socket and Ratchet on the nut end and the 9/16" (14mm) Wrench on the bolt end. Tighten until snug and repeat with remaining clip.



#### STEP EIGHT

Turn the assembly upright again. At this time, if the cord contains a metal strain relief, you can use the chain connector and attach it in one of the opening at the rope placement. The chain connector will easily fit if installed from the bottom or top side of the opening. It will not fit if installed from side of opening. Use the Nylon Cable Tie included to secure the power cord to a molded hole in the float to prevent cord damage if there is no strain relief on the cord. If a Strain Relief is present on the cord, you may disregard the Nylon Tie. On cords with a Quick Disconnect, the disconnect should be tightened properly to avoid leaking. If installing a new Quick Disconnect, refer to Quick Disconnect Instructions.



## 8400VFX & 5.1VFX Parts

### 8400VFX PARTS INCLUDED

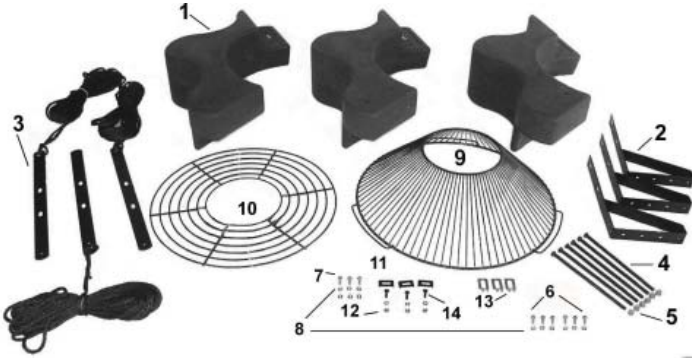

### 5.1VFX PARTS INCLUDED



A. 8400VFX or 5.1VFX Aerating Fountain (Unit with cord or unit with Disconnect) (1)

A1. Cord in separate box (1) (depending on size of cord)

B. Float in separate box (1) (Diagram to Right)

1. 3 Float Sections (1)
2. Top Float Bracket (3)
3. Bottom Float Bracket w/ 50' rope (3)
4. 9" x 3/8" Black Coated Bolt (6)
5. 3/8" Lock Nut (6)
6. 1/4" x 1" Bolt (6)
7. 1/4" x 3/4" Bolt (3)
8. 1/4" Lock Washer (12)
9. Bottom Screen (1)
10. Top Screen (1)
11. Top Screen Clip (3)
12. 1/4" Nut (6)
13. Bottom Screen Clip (3)
14. 1/4-20 x 3/4" Brass Screw (3)

C-85 Control Panel in separate box (1) *for 8400VFX*

C-95 Control Panel in separate box (1) *for 5.1VFX*

NOTE: Extra hardware may be included.

## TOOLS & SUPPLIES NEEDED

- Anchors or stakes for installing unit (3)
- Philips head screw driver for mounting C-85
- 240V Electrical Supply near pond on a post with room for mounting the C-85
- Three 12" long galvanized 1" diameter pipe for weighting ropes (optional)
- #10 x 1" long or longer screw(s) for mounting the C-85 (4)
- 7/16" Socket & Wrench (1)
- 7/16" Wrench (1)
- 9/16" Socket & Wrench (1)
- 9/16" Wrench or adjustable crescent wrench (1)
- Flat head screw driver (1)

## 8400VFX & 5.1VFX Assembly

### STEP ONE

Remove all contents from package and place on a clean, flat surface. Inspect the shipment for any damages. If damages are found, immediately notify your carrier and your Kasco Marine, Inc. representative. Next, cross reference the parts included in the shipment with the Parts Included section in this manual. Make sure you have all the parts needed. If any shortages are found, contact your Kasco representative immediately.

### STEP TWO

Arrange the three Float Sections (Part #B1) upright (plug on bottom) so the overlap of one section aligns with the next section and loosely push the three sections together to form a continuous ring.

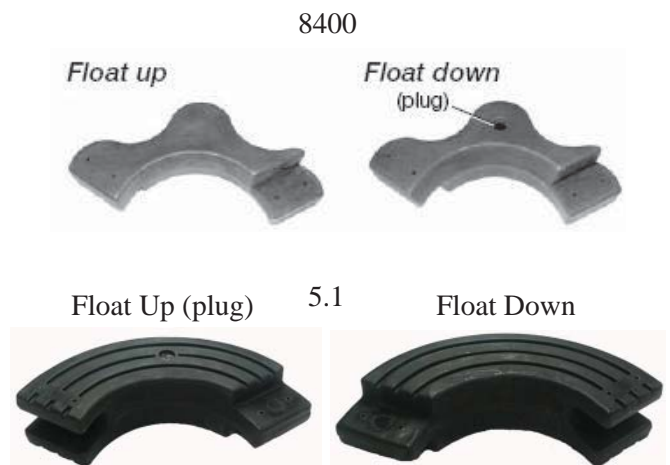

8400



5.1

**STEP THREE**

Position one Top Float Bracket (Part #B2) so that the bolt holes in the bracket align with the bolt holes in the two adjoined float sections and insert two 9" Coated Bolts (Part #B4) through the assembly. This may require some minor repositioning of the float sections as you push the bolt all the way through. Do not force the bolt through. Repeat for the remaining two joints.

8400

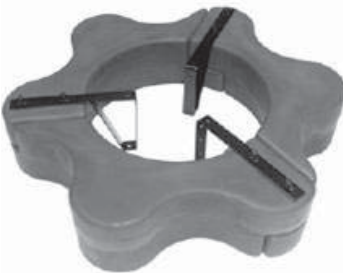

5.1

**STEP FOUR**

Turn the assembly upside down and place the Bottom Float Brackets (Part #B3) over the bolts, the ends of which should now be extending through the assembly. Loosely install the six 3/8" Lock Nuts (Part #B5) on the ends of the bolts (do not tighten yet). Connect the Top and Bottom Float Brackets using three 1/4" x 3/4" Bolts (Part #B7) with three 1/4" Lock Washers (Part #B8) and three 1/4" Nuts (Part #B12) and tighten using the 7/16" wrench and socket.

8400



5.1

**STEP FIVE**

Stand the assembly on its side and center the Top Screen (Part #B10) inside the three Top Float Brackets. Attach the screen by spanning each Top Screen Clip (Part #B11) across the two innermost rings on the

screen and the hole in the float bracket. Insert the 3/4" Brass Screws (Part #B14) and attach with 1/4" Lock Washers and 1/4" Nuts to secure the screen to the float assembly.

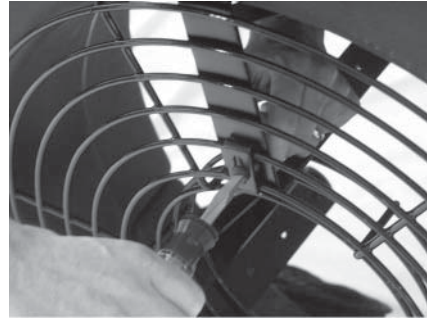
**STEP SIX**

Return the assembly to the upside down position and place the motor assembly (Stainless Steel can side up, black tube down) in the center of the float. Align the 3 taller legs of the black fountain tube with the 3 float brackets. Attach the motor to the float using the 1/4" x 1" bolts (Part #B6). Attach to the float bracket using the two middle holes of the float bracket. Tighten using the 1/4" x 1" Bolts with 1/4" Lock Washers using the 7/16" socket and wrench. The 1" bolts will screw directly into the legs of the black fountain tube.

**Step 6****STEP SEVEN**

Position the Bottom Screen (Part #B9) over the float so the motor housing (can) passes through the large hole in the center of the screen. Remove the center three 3/8" Lock Nuts from the 9" Bolts and place the Bottom Screen Clips (Part #B13) over the bolts as shown. The power cord can be slid under the bottom screen between the float and screen where two float sections come together before the 3/8" Lock Nuts are replaced. Replace the three inside Lock Nuts and

tighten all 3/8" Lock Nuts using the 9/16" wrench and socket.

8400

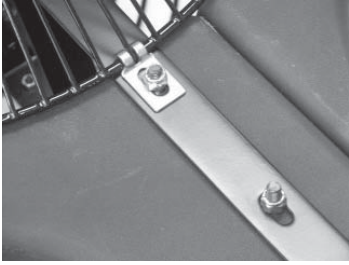

5.1



Note: Extra hardware may be included

### STEP EIGHT

On power cord lengths of 100 feet or longer with the watertight Quick Disconnect, the power cord is shipped separately. It should now be attached to the stub cord by lining up the male and female halves of the disconnect and hand tightening the blue collar. On these cords, the Additional Strain Relief should be attached to one of the lower float brackets as pictured. If there is not Strain Relief, use the Nylon Cable Tie provided to secure the cord to a rope to prevent damage by the propeller. Double check the Quick Disconnect to make sure the threaded collar has not come loose in shipping before placing in the water. If installing a new Quick Disconnect, please refer to Quick Disconnect instructions. Also, at this time, lights can be installed if purchased



8400



5.1



## VFX Installation Instructions

Use the ropes to position the Fountain in the desired location in the pond/lake. Anchor the ropes or secure them to the shoreline so the ropes are free of slack, but not tight. To prevent twisting of the unit due to torque, you should place the anchor at least 3 feet from the float for each foot of depth (Ex. A 6 foot deep pond would require an anchor 18 feet horizontally from the float.)

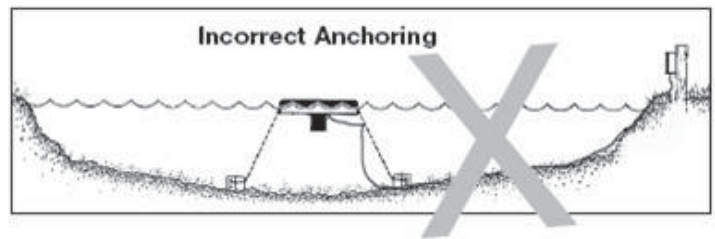
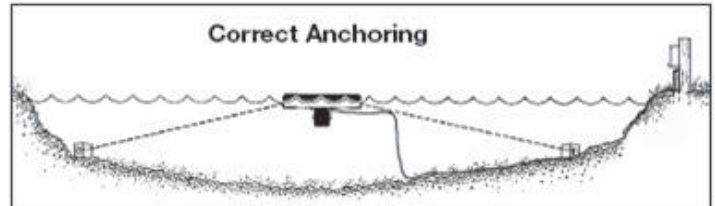

### ALTERNATE INSTALLATION

In ponds where the water level fluctuates significantly, you may need to suspend a small weight (12" of 1" galvanized pipe works well) at the mid-point of the rope to take up any slack as the water level drops. The weight should be light enough so the Fountain can rise as the water level rises. This can also help hide ropes by sinking them further below the surface.

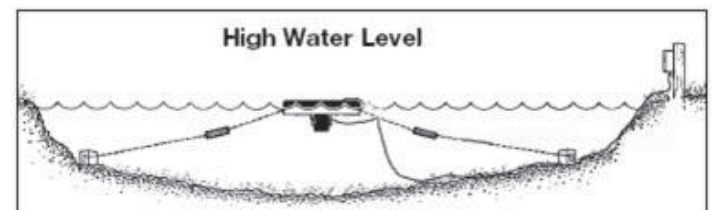
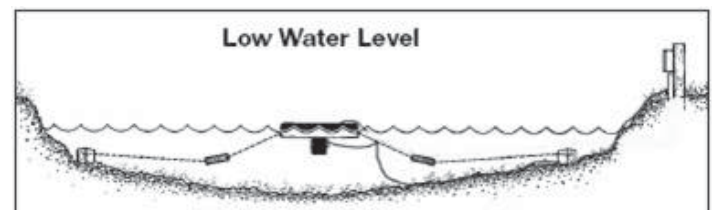
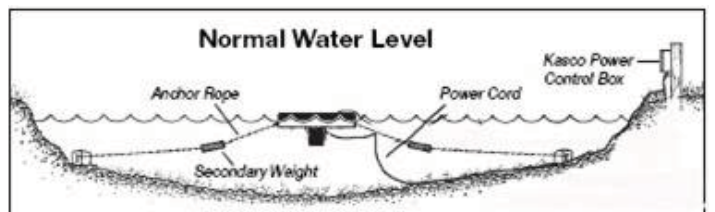

# Control Panel Installation

## STEP ONE

Install the control panel (C-25 for 120V and C-85 or C-95 for 240/208V/) on the post with the power supply. Use the #10 x 1" long or longer screws and the screw placements on the control panel to secure the panel to the post. NOTE: The control panel must be hung upright in order to be rain tight.

## STEP TWO

Set Timer in the control panel to desired ON and OFF times per the Instructions for each specific timer. Make sure to test the GFI using the Test Button located on the outlet before turning the equipment on and every 30 days thereafter.

## STEP THREE (For 120V Installations)

Plug the aerating fountain cord into the C-25 outlet labeled "UNIT". If lights are included, plug the Transformer cord into the C-25 outlet labeled "LIGHT". Now you are ready to plug the C-25 into the 120V power supply on the post and ENJOY YOUR NEW KASCO AERATING FOUNTAIN!

## STEP THREE (For 240V Installation)

Electrical Service wiring: To hardwire the 240V or 208V - 4 wire service (L1, L2, N, & G) to the C-85 or C-95 control panel please refer to the panel's inner door label or the label printed in this manual. Follow all local and national electrical codes for this installation and Consult a qualified electrician or service person if needed.

Hardwiring the Fountain: The bottom of the C-85 and C-95 control panels have several knock-outs that can be removed to hardwire the unit. Remove a knock-out that will not be used for the main power. Install a strain relief fitting to secure the fountains power cord, or you may need to install the power cord in a conduit if required. Consult your electrician.

For the C-95, use the terminal block near the bottom of the panel to hardwire the fountain. Refer to the C95 inner door label wiring diagram. The GREEN ground wire is attached to the left terminal, the WHITE wire is connected to the middle, and the BLACK wire is connected to the right

terminal.

For the C-85, with the main power disconnected, connect the GREEN ground wire to the grounding strip at the bottom of the panel and secure tightly. Locate and remove the plastic shield on the yellow timer (black or clear depending on model). Under the shield, terminal #2 and #4 are LOAD terminals to supply power to the fountain. Loosen the screws and remove the existing wires that connect the external outlet on the side of the panel. Cap these wires off individually with wire nuts. This will disconnect the power from the outlet on the side of the panel. Insert the WHITE wire under the #2 terminal on the timer and the BLACK wire under the #4 terminal. Tighten both terminals securely. Replace the timer cover and the metal barrier plate in panel.

Test the GFCB with the test button now and every 30 days. If lights are installed, they can now be installed per Instructions included with the lights.

C85

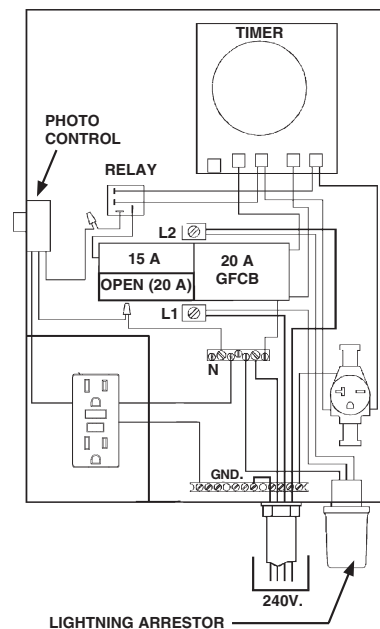



# MODEL: C85

DISPLAY AERATOR CONTROL WITH TIME SWITCH, GFCB,  
LIGHTNING ARRESTOR AND 15 AMP GFCI LIGHTING RECEPTACLE  
SUITABLE FOR USE WITH SUBMERSIBLE LIGHTS

IN RAINPROOF (TYPE 3R) ENCLOSURE SUITABLE FOR INDOOR OR OUTDOOR USE  
40 AMP. MAX PER LEG 120/240 VOLT SINGLE PHASE (THREE WIRE) AC

PUMP CIRCUIT: 3 hp max, 240 Vac, LIGHT CIRCUIT: 120 Vac - 15 amp Max.

MIN 75° C SUPPLY CONDUCTORS

PHOTO CONTROL RATINGS: 120 VAC 50/60 HZ. 1800W TUNGSTEN, 8.3A BALLAST

LIGHTNING ARRESTOR RATINGS: 120/240 VAC; MCOV 250 VAC

*Note: The short circuit current rating of this panel is 10,000 symmetrical amperes.*



**IMPORTANT:** This control panel must be installed according to the National Electrical Code (including article 680) and local code requirements. The main lugs and neutral main are suitable for No. 14 to 2 AWG **COPPER** conductors. Follow gauge selection table and corresponding terminal screw tightening torque requirements below. An additional branch circuit protector (20 Amp max) may be installed in the unused position for use as an auxiliary circuit. Use only Square D HOM Series circuit breakers for addition or replacement (do not exceed ratings on wiring diagram). Follow Manufacturers instructions for testing of ground fault circuit breakers (GFCB). This panel is equipped with a 120V AC - 15 amp duplex GFCI receptacle for connecting a 120V AC light kit or an external low voltage transformer for lighting. The receptacle power is controlled by the timer-photoelectric circuit. Refer to the instructions provided with your light kit. After wiring, install front panel over wiring compartment.

**KEEP DOOR CLOSED AT ALL TIMES.**

Wiring information-Copper Conductors	
Wire Size	Terminal Tightening Torque
AWG	Lb-In
14	20
12	20
10	20
8	25
6	35
4	45
3	50
2	50

## TIME SWITCH OPERATING INSTRUCTIONS

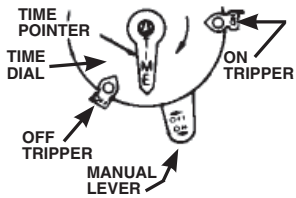

### 1. TO SET "ON" AND "OFF" TIMES:

Hold TRIPPERS against edge of CLOCK-DIAL, pointing to time (AM or PM) when **ON** and **OFF** operations are desired. Tighten tripper screws firmly.

### 2. TO SET TIME-OF-DAY:

Pull CLOCK-DIAL outward. Turn in either direction and align the exact time-of-day on the CLOCK-DIAL (the time now, when switch is being put into operation) to the pointer.  
-DO NOT MOVE POINTER-

- **TO OPERATE SWITCH MANUALLY:** Move MANUAL-LEVER below left or right as indicated by arrows. This will not affect the next operation.
- **FOR MORE THAN ONE DAILY ON-OFF OPERATION:** Place additional tripper pairs on CLOCK-DIAL (order 156T1978A).
- **IN CASE OF POWER FAILURE:** Reset CLOCK-DIAL to proper time of day. See step 2 above.

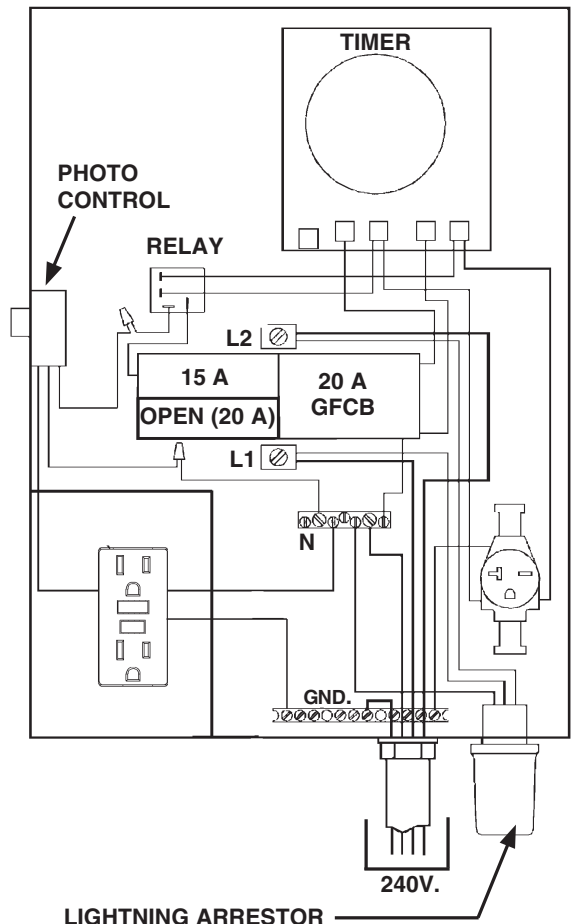

**KASCO MARINE, INC.,**  
800 Deere Road  
Prescott, WI 54021-1241  
• Phone (715) 262-4488

158PS13244

# MODEL: C95

**DISPLAY AERATOR CONTROL WITH TIME SWITCH, GFCB, LIGHTNING ARRESTOR AND 15 AMP GFCI LIGHTING RECEPTACLE SUITABLE FOR USE WITH SUBMERSIBLE LIGHTS**

IN RAINPROOF (TYPE 3R) ENCLOSURE SUITABLE FOR INDOOR OR OUTDOOR USE  
40 AMP. MAX PER LEG 120/240 VOLT SINGLE PHASE (THREE WIRE) AC  
PUMP CIRCUIT: 24 FLA, 144 LRA, 240 Vac, LIGHT CIRCUIT: 120 Vac - 15 amp Max.  
MIN. 75° C SUPPLY CONDUCTORS

PHOTO CONTROL RATINGS: 120 VAC 50/60 HZ. 1800W TUNGSTEN, 8.3A BALLAST  
LIGHTNING ARRESTOR RATINGS: 120/240 VAC; MCOV 250 VAC



**IMPORTANT:** This control panel must be installed according to the National Electrical Code (including article 680) and local code requirements. The main lugs and neutral main are suitable for No. 14 to 2 AWG **COPPER** conductors. Follow gauge selection table and corresponding terminal screw tightening torque requirements below. An additional branch circuit protector (20 Amp max) may be installed in the unused position for use as an auxiliary circuit. Use only Square D HOM Series circuit breakers for addition or replacement (do not exceed ratings on wiring diagram). Follow Manufacturers instructions for testing of ground fault circuit breakers (GFCB). This panel is equipped with a 120V AC - 15 amp duplex GFCI receptacle for connecting a 120V AC light kit or an external low voltage transformer for lighting. The Pump Terminal Bar is controlled by the timer only. The Lighting GFCI outlet is controlled by the timer and photoelectric circuit. Refer to the instructions provided with your light kit. After wiring, install front panel over wiring compartment.

**KEEP DOOR CLOSED AT ALL TIMES.**

Wiring information-Copper Conductors	
Wire Size	Terminal Tightening Torque
AWG	Lb-In
14	20
12	20
10	20
8	25
6	35
4	45
3	50
2	50

## TIME SWITCH OPERATING INSTRUCTIONS

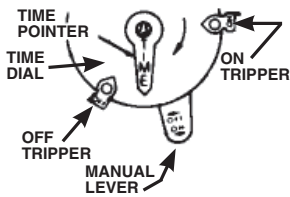

### 1. TO SET "ON" AND "OFF" TIMES:

Hold TRIPPERS against edge of CLOCK-DIAL, pointing to time (AM or PM) when **ON** and **OFF** operations are desired. Tighten tripper screws firmly.

### 2. TO SET TIME-OF-DAY:

Pull CLOCK-DIAL outward. Turn in either direction and align the exact time-of-day on the CLOCK-DIAL (the time now, when switch is being put into operation) to the pointer.

**-DO NOT MOVE POINTER-**

- **TO OPERATE SWITCH MANUALLY:** Move MANUAL-LEVER below left or right as indicated by arrows. This will not affect the next operation.
- **FOR MORE THAN ONE DAILY ON-OFF OPERATION:** Place additional tripper pairs on CLOCK-DIAL (order 156T1978A).
- **IN CASE OF POWER FAILURE:** Reset CLOCK-DIAL to proper time of day. See step 2 above.

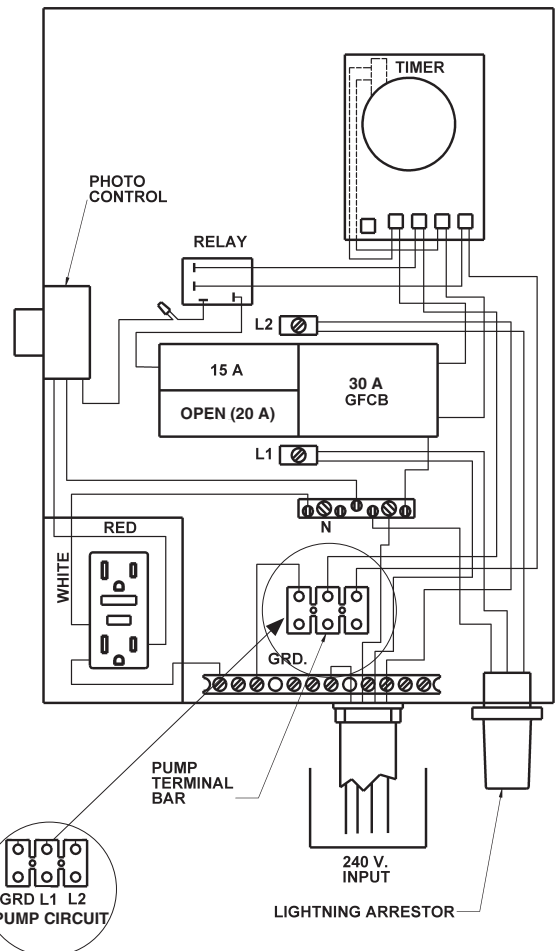

**KASCO MARINE, INC.,**

800 Deere Road  
Prescott, WI 54021-1241

• Phone (715) 262-4488

158PS13206

## Maintenance Recommendations

**\*\* Under No Circumstances should anyone enter the water while a fountain is operating.**

**\*\***

**\*\* Please keep the original box for maintenance shipping. \*\***

The following maintenance procedures can be utilized to ensure many years of quality performance from your Kasco Fountain and reduce the need for more costly repair work.

**PROPER INSTALLATION:** Proper installation of Kasco equipment will include a power source with ground fault interruption (GFI). For Fountain models, the C-25 control (120V) or C-85 (240/208V) included with the unit have built-in ground fault interruption that is sufficient. Ground fault interrupters are a safety feature that can also alert you to electrical leaks in the equipment. It is extremely important to test the GFI upon installation, each reinstallation, and monthly thereafter to ensure proper operation. If you have repeat, consistent trips on your ground fault, the equipment should be disconnected and removed from the water. The power cord should be inspected for damage and you should call Kasco Marine at 715-262-4488 for further instructions or email Kasco at [service@kascomarine.com](mailto:service@kascomarine.com).

**OBSERVATION:** Operating equipment should be observed on a regular basis (daily, if possible) for any reduction or variation in performance. If a change in performance is observed, the equipment should be disconnected from power and inspected for any material that may have clogged the system or wrapped around the shaft of the motor, especially plastic bags and fishing line. Even though Kasco Aerators and Fountains are among the most

clog-resistant on the market, it is impossible to protect against all items that can clog equipment and still maintain a flow of water. These materials can be very damaging to the equipment under continued operation and must be removed as soon as possible. **ALWAYS UNPLUG THE UNIT BEFORE ATTEMPTING TO REMOVE CLOGS.**

**WINTER STORAGE:** In regions where there is significant freezing in the wintertime, the fountains should be removed from the water to protect them from the expansion pressure of the ice. In many areas, fountains will keep some amount of ice open through the winter. However, when the water is thrust into the air, it is exposed to the colder air temperatures longer and can actually make ice thicker on the pond/lake. Storage over winter is best in a location that is out of the sun and cool, but above 32°F. It is not necessary to store Kasco motors upside down. All internal seals are fully lubricated while stored in an upright position.

**CLEANING:** Fountains should be removed from the water at least once per year (at the end of the season in cold climates) to clean the exterior of the system, especially the stainless steel motor housing (can). The motor housing is the surface that dissipates heat into the water and any algae, calcium, etc. build-up will become an insulator that blocks heat transfer. In warmer regions it is recommended that the motor is removed and cleaned at least two to three times per year depending on conditions. In most cases a power washer will be sufficient if the unit and algae are still wet.

**SEAL AND OIL REPLACEMENT:** This is a sealed motor assembly and seals will wear out over time (similar to break pads on a car). Replacement of the seals and a change of oil after

three years may add longevity to the operation of the motor, saving you the cost of more expensive repairs. In warmer climates where the fountain runs most or all of the year, it is a good idea to replace seals more regularly than you would need to in colder climates where the unit is removed from the water for several months.

**ZINC ANODE:** A Sacrificial Zinc Anode is supplied on the shaft of all VFX Model Fountains for protection of the equipment from corrosion and electrolysis. The zinc anode should be updated (replaced) if reduced to half the original size or if white in color. Corrosion from electrolysis is more commonly associated with saltwater or brackish water, but as a matter of precaution, it is important to periodically check the zinc anode in all installations (at least every two to three months).

Seal replacement and all other repair services should be performed by Kasco Marine or a Kasco trained Authorized Repair Center. Any alterations or changes made to Kasco units by an unauthorized source will void the warranty. This includes tampering with the unit, power cord, and/or control box. Please contact Kasco Marine, Inc. at 715-262-4488 for your nearest Authorized Repair Center.

## Warranty Policy

### Warranty Period:

Models: 2400VFX, 3400VFX,  
3400HVFX, 4400VFX, 4400HVFX - 2 years

Models: 8400VFX, 5.1VFX - 3 years

Kasco® Marine, Inc. warrants this Fountain to be free from defects in material or workmanship (except for the ropes, power cord, and

propeller) under normal use and service. The Kasco Marine, Inc. obligation under this warranty is limited to replacing or repairing free of charge any defective part within the warranty period from the date of shipment. Customer shall pay shipping charges for returning the unit to Kasco or an Authorized Repair Center.

**THIS WARRANTY IS IN LIEU OF ANY OTHER WARRANTIES, EXPRESSED OR IMPLIED, AND ANY OTHER OBLIGATION OR LIABILITY WHATEVER ON THE PART OF KASCO MARINE, INC. AND IN NO EVENT SHALL KASCO MARINE, INC. BE LIABLE FOR ANY SPECIAL OR CONSEQUENTIAL DAMAGES.**

Warranty is void if:

- The Fountain is not maintained properly according to the Maintenance Recommendations supplied in this Owners Manual.
- The Fountain is returned for repair without the power cord or if the unit, control box, or power cord are altered in any way from original shipment. Cuts in the power cord are not covered under warranty.
- The Fountain is damaged by unauthorized tampering.
- The Sacrificial Zinc Anode around the propeller shaft shows significant deterioration. (The Anode must be inspected periodically and replaced if necessary.)

### Warranty Claim Procedure:

Check the eleven-digit serial number printed either on the black cover of the motor or on the blue nameplate and determine the year of manufacture according to the serial number scheme below:

Sample Serial #  
70 01 VX 2 1725

The first two digits represent the reverse of the last two digits of the year of manufacture.

Example: 80 = 2008 model year.

The third and fourth digits represent the week of the year. (Ex. "01" for 1st week in Jan.) model.

The best method for establishing warranty period is by keeping your original receipt. Also register the Fountain online at:

[www.kascomarine.com](http://www.kascomarine.com) (under technical tab) Kasco Marine will have a record of the purchase and will be able to determine whether or not the unit still carries warranty coverage.

Once the warranty coverage has been established, the unit may be sent to any Kasco Authorized Repair Center for evaluation and repair. Please call Kasco Marine at 715-262-4488 prior to shipping.

Kasco Marine, Inc.  
800 Deere Rd.  
Prescott, WI 54021  
Attn: Repairs

Or call Kasco Marine at 715-262-4488 to locate your nearest Authorized Repair Center. You can also email Kasco at [service@kascomarine.com](mailto:service@kascomarine.com)

Note: Only complete motor assemblies will be accepted for warranty repair. The power cord and all other components must be returned with the motor as originally assembled. Any missing parts will be replaced at the customer's expense and, if determined to have caused the failure, could void the entire warranty. Some parts are essential for structural support during shipping and others, such as the power cord, are essential to properly diagnose potential causes of failure. It is not necessary to return the control box or float with the motor

assembly.

Please include the Repair Form received from Kasco Marine or your local distributor with the shipment. If no Repair Form is available, include your name and physical address for return delivery of the repaired unit and a daytime phone number and/or e-mail address for correspondence regarding the warranty claim.

Any expedited shipping method for the return of the unit is at the customer's expense. Kasco Marine will return units repaired under warranty at our expense via ground freight within the continental United States.

#### Other Repairs:

Most failed equipment can be repaired at substantially lower costs than replacement with new. Please ship according to the instructions in the previous section. Again, it is best to call ahead for a Return Authorization Number and/or Repair Form so we know the repair is coming.

Kasco Marine does estimates on repairs at the request of the customer. The request for estimate should be included in the letter that accompanies the returned unit and must include a daytime phone number and/or e-mail address. Estimate options are as follows:

We will contact the customer with a total after the unit has been evaluated, but before the work is performed.

We will repair the unit only if repair costs are under a stated dollar amount. Example: "Please repair if total is under \$150.00 before shipping charges."

All estimates that are rejected for repair will be destroyed unless otherwise directed by the customer. If the customer would like the unit

returned, the unit will be restored as closely as possible to the condition in which it was received and shipped at the customer's expense for shipping and handling charges.

### Billing:

All non-warranty repairs will be returned to the customer prepaid with Visa or Mastercard or shipped C.O.D. with C.O.D. charges unless otherwise directed. Kasco Marine will call for credit card information upon completion of the repair.

All other warranty and repair inquiries should be directed to Kasco Marine, Inc. at 715-262-4488 or [returns@kascomarine.com](mailto:returns@kascomarine.com)

### Troubleshooting Tips

Below are some helpful troubleshooting tips. If a problem occurs, please double check the assembly and installation instructions as well as the instructions for the proper control panel. More troubleshooting tips can be found at [www.kascomarine.com](http://www.kascomarine.com) (under the technical tab)

*“My Fountain trips the ground fault interrupter in the C-25, C-85, or C-95.”*

This is the most common symptom of several possible problems. To correctly diagnose the problem, you will need to collect more information. A Ground Fault Interrupter (GFI) breaker that trips can indicate an electrical service problem, water contamination in the unit and/or cord, bad breaker, control box problems, motor problems, etc. Try to find out the answers to these questions before you contact Kasco to narrow down the problem.

- How long does it take to trip the breaker?

- Does it always take the same amount of time to trip?
- How many times has it tripped?
- Has there been any electrical problems in the area recently?

*“My Fountain seems to run slowly.”*

This can also be a symptom of several possible problems. There could be an electrical problem where the unit is not getting the proper voltage. This could also indicate a problem with the motor of the unit, which needs to be looked at by an Authorized Repair Center. Check that the unit is receiving the proper voltage, and, if so, contact Kasco for further steps.

*“My Fountain hums, but will not start. When I spin the prop with a stick, it starts up.”*

This indicated a problem with the Starting Capacitor. Each Kasco Fountain is equipped with a Starting Capacitor to get the unit going when it is first plugged in. If it is operating, but not spinning and can be started by spinning the prop with a stick, the Starting capacitor needs to be replaced by an Authorized Repair Center.

*“My Fountain turns itself off and back on without the timer and without tripping the GFI breaker.”*

Each Kasco Fountain has a Thermal Overload built in that will turn the unit off when it overheats. Once the unit has cooled down, it will start back up. If you are noticing these symptoms, the unit should be unplugged immediately because the Thermal Overload will continue to turn on and off until it burns out and damages the motor. The unit should be unplugged and taken out of the water to find the cause of the problem. The problem could be one of many, such as, low water levels, build-up on the unit to prevent heat dis-

sipation, something inhibiting the free rotation of the shaft, etc. If something is caught in the unit or there is a build-up of algae, calcium or organic matter on the unit, remove the debris and, if caught early enough, the unit should be fine. Contact a Kasco representative before restarting the unit.

*“My Fountain flow seems to fluctuate and/or be less than usual.”*

This can occur because of a few different reasons. Most of the time, this symptom is caused from unit being clogged with debris. A mat of weeds, many leaves, plastic bags, etc. can clog up the unit and cause it to be starved of water. If the unit does not have the proper amount of water, the flow or pattern will fluctuate up and down and look sporadic. If you are seeing these symptoms, unplug the unit and clean away the debris that is clogging up the screen. Another possibility if these symptoms are noticed, is a chipped or damaged prop that is causing the unit to wobble and not pump properly. When the unit is unplugged, check the prop for damages and replace if damage is found.

*“The GFI breaker trips randomly and sporadically. Sometimes it is a few hours of operation, other times it can be days or weeks.”*

This is referred to as a Nuisance Trip. This usually occurs where the unit is installed a great distance from the initial electric service on the property where the ground stake is placed. It is caused by either induced current in the ground wire or a base voltage difference due to soil pH levels. To resolve the problem, contact an electrician and install a local grounding stake. This may eliminate the induced current and any base voltage differences. This problem can also be caused by a bad breaker or receptacle or having unbalanced incoming voltage lines.

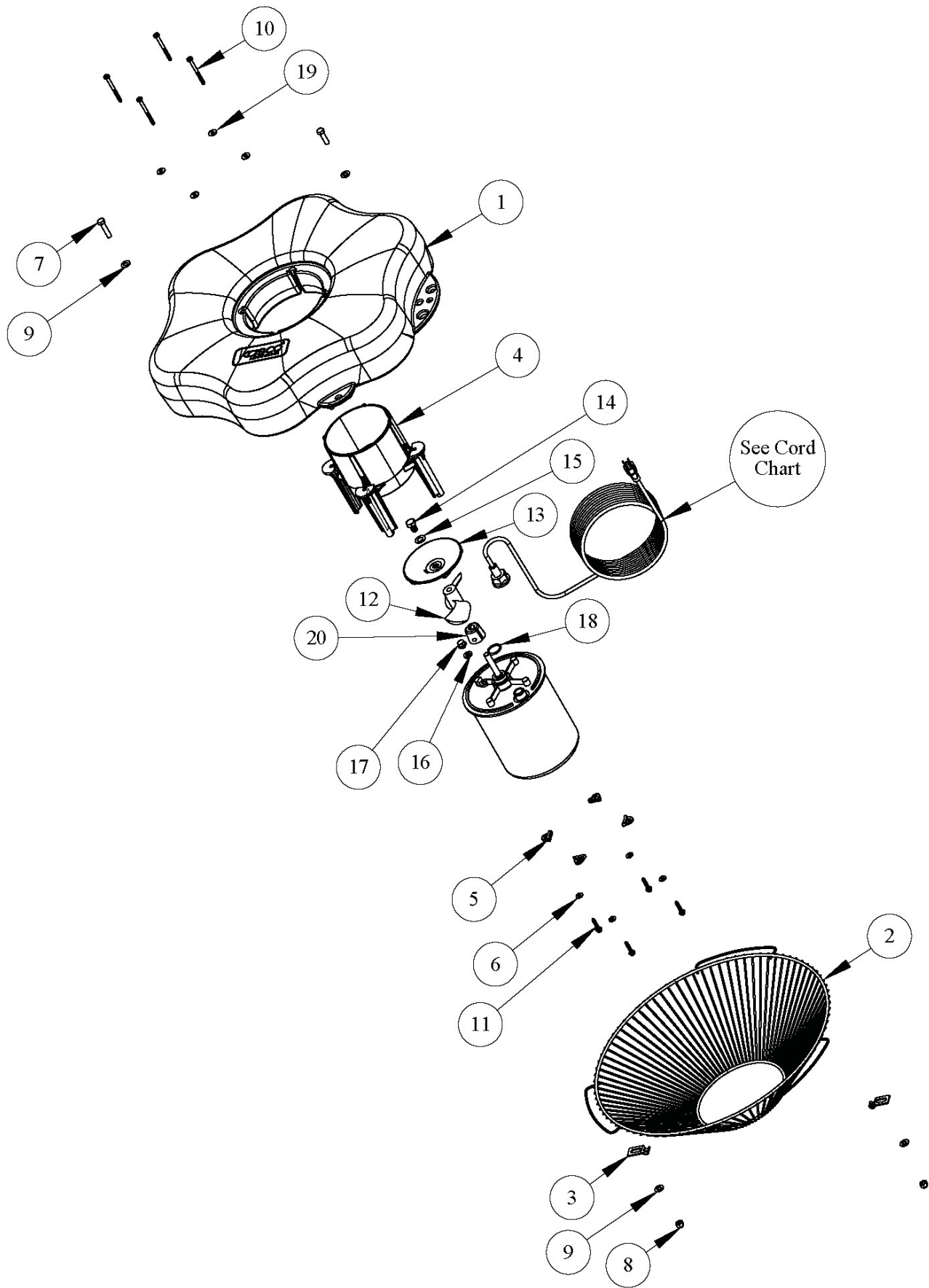

# 8400VFX REPLACEMENT PARTS

ITEM NO.	PART NO.	DESCRIPTION	8400VFX /QTY.
1	990275	O RING, CORD	1
2	990280	SEALING PLUG	1
3	990281	O RING	1
4	840475	ZINC ASSEMBLY	1
5	140312	RETAINING CLIP	6
6	584692	1/4-20 X 1-3/8" BOLT	6
7	821100	TOP DISK, 8400VFX	1
8	821120	8400VFX TUBE	1
9	821095	1/2-20 HEX NUT, LEFT HAND THREADED	1
10	475642	WASHER, 1/2"	2
13	821114	PROP.3.1A/8400VFX, TRIMMED	1
14	840537	LOCK WASHER, 1/4"	6

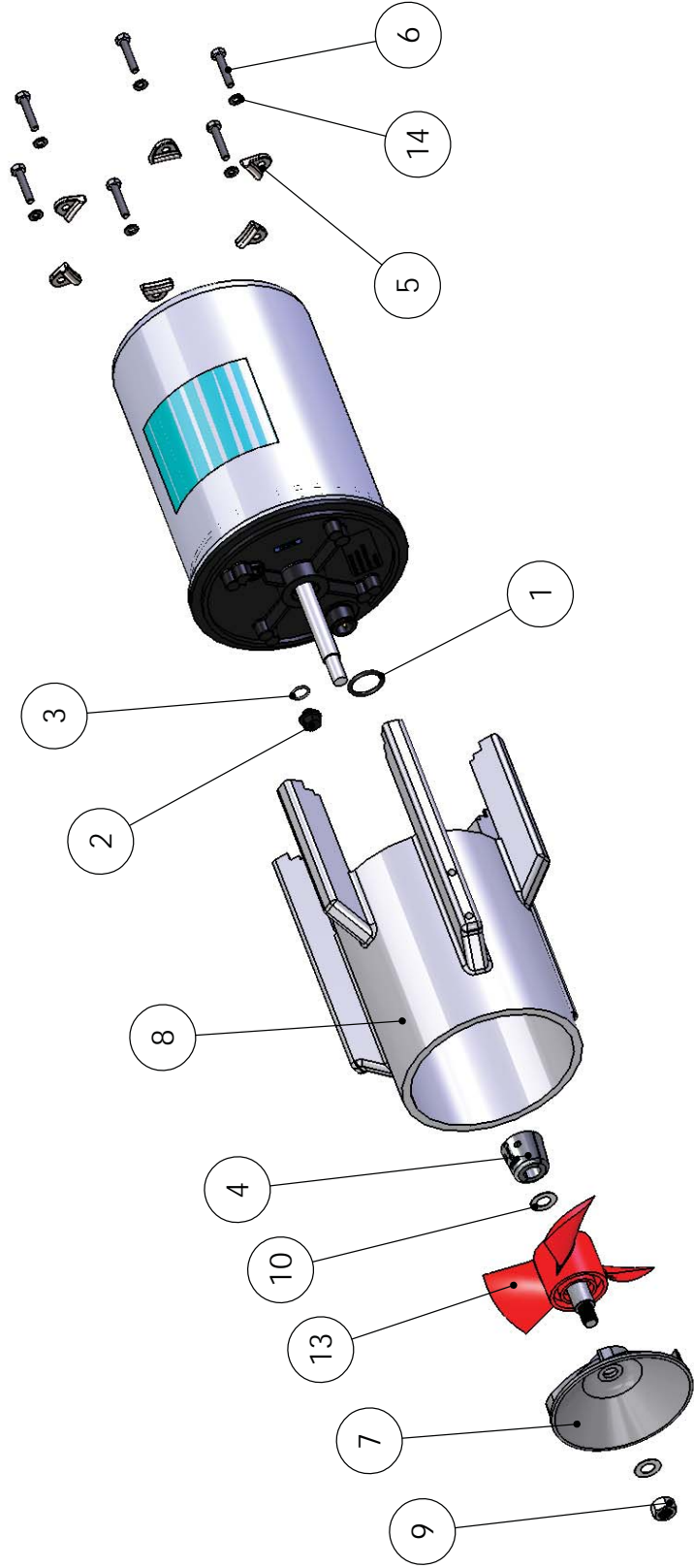

# 5.1VFX REPLACEMENT PARTS

ITEM NO.	PART NO.	DESCRIPTION	5.1VFX PARTS LIST/QTY.
1	990290	O RING	1
2	990280	SEALING PLUG	1
3	990281	O RING	1
4	840475	ZINC ASSEMBLY	1
5	140312	RETAINING CLIP	6
6	840537	LOCK WASHER, 1/4"	6
7	584692	1/4-20 X 1-3/8" BOLT	6
8	475642	WASHER, 1/2"	2
9	821124	PROP, 5.1A/5.1VFX,	1
10	821095	1/2-20 HEX NUT, LEFT HAND THREADED	1
11	510250	5.1VFX TUBE	1
12	510200	TOP DISK, 5.1VFX	1

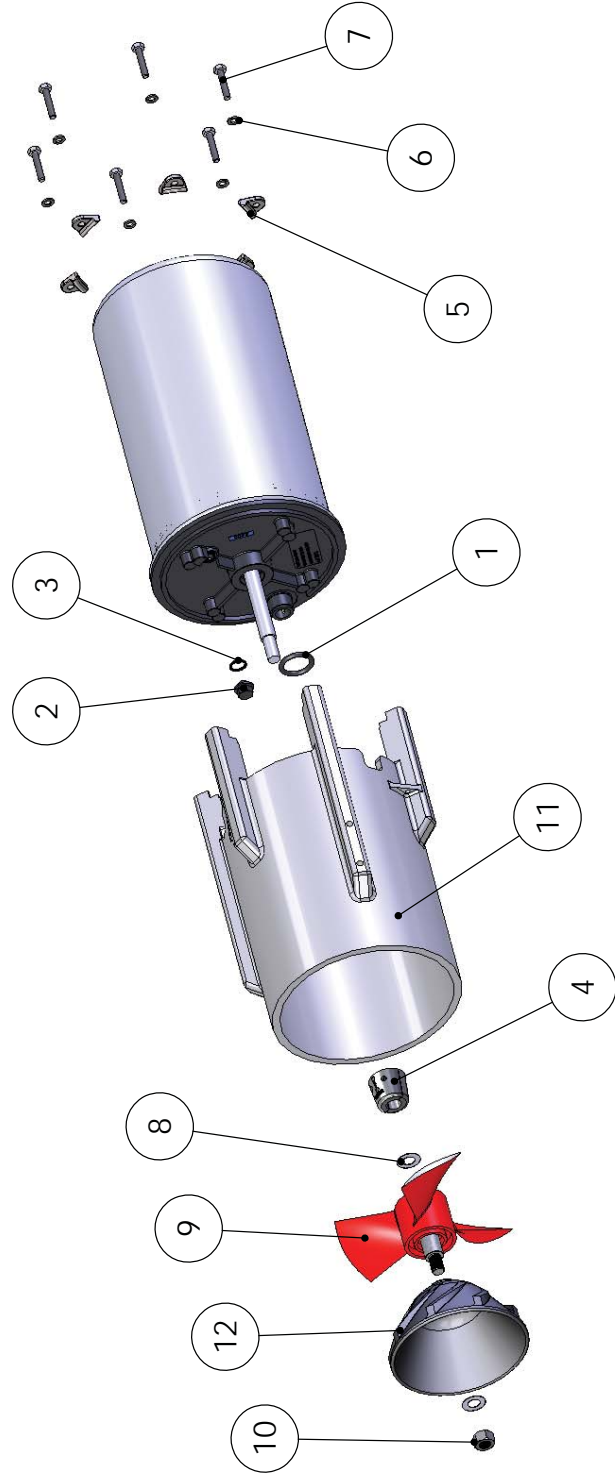



800 Deere Rd.  
 Prescott, WI 54021  
 Phone: 715-262-4488 - Fax: 715-262-4487  
 www.KascoMarine.com Sales@KascoMarine.com

## Customer Repair Form

**\* Important Reminders \***

- All repairs sent in **MUST** be accompanied by a copy of this completed sheet!
- Routine maintenance consists of checking the zinc anode regularly and replacing if necessary, keeping the unit clean, keeping the stainless steel can clean, and having the seals and oil replaced every 3-5 years depending on use.
- Address your Repair to Kasco Marine, Attn: Repairs (or to your Authorized Repair Center).
- Shipping to Kasco or an Authorized Repair Center is paid for by the customer.
- You must include the power cord and cage assembly with each unit sent in for repair to be considered for warranty repair!
- Do not ship the float and/or control box with the unit for repair, unless otherwise instructed.

Today's Date: \_\_\_\_\_

**Customer Information**

Name: \_\_\_\_\_

Phone Number: \_\_\_\_\_

Address: \_\_\_\_\_

Alternate Number: \_\_\_\_\_

City: \_\_\_\_\_

Email Address: \_\_\_\_\_

State: \_\_\_\_\_

Zip Code: \_\_\_\_\_

**Unit Information:**

Model # (Ex. 1400JFL): \_\_\_\_\_

Serial # (Ex. 7001JL14025): \_\_\_\_\_

Date Purchased: \_\_\_\_\_

Purchased From: \_\_\_\_\_

Earliest Date of Problem: \_\_\_\_\_

Description of Problem:

Comments:

## Registration Information

Please register your fountain online at:

[www.kascomarine.com](http://www.kascomarine.com) (Under the Technical Tab)

Also fill in the information below and keep for your records.

Model # (Ex. 5.1VX) \_\_\_\_\_

Serial # (Ex. 8001VX511725) \_\_\_\_\_

Purchase Date: \_\_\_\_\_

Purchased From: \_\_\_\_\_

Registration Date: \_\_\_\_\_



Kasco Marine, Inc.  
800 Deere Rd.  
Prescott, WI 54021

Phone (715) 262-4488 \* Fax (715) 262-4487

[www.kascomarine.com](http://www.kascomarine.com) \* [sales@kascomarine.com](mailto:sales@kascomarine.com) \* [service@kascomarine.com](mailto:service@kascomarine.com)